

Rammer® E01

EXCELLENCE LINE COMPACT RANGE HAMMER



Rammer's world-renowned Excellence line completes with the Compact range hammers, which offer versatile, reliable solutions for construction applications.

APPLICATIONS



Excavation



Building Construction

MAIN FEATURES AND BENEFITS

THE MOST EFFICIENT OPERATIONS:

- CBE enables plug-and-play installation
- High uptime and easy maintenance based on membrane accumulator
- Compact, right size for the job – optimized fuel consumption

LONG LIFETIME AND SUITABILITY FOR DIFFERENT APPLICATIONS:

- Durability based on the highest quality materials and cast body protection by optional wear plates
- Modular body design structure enables versatile use through the whole lifecycle



The hammer in the picture is equipped with optional: wear plates, automatic greasing device, RD3

Rammer® E01

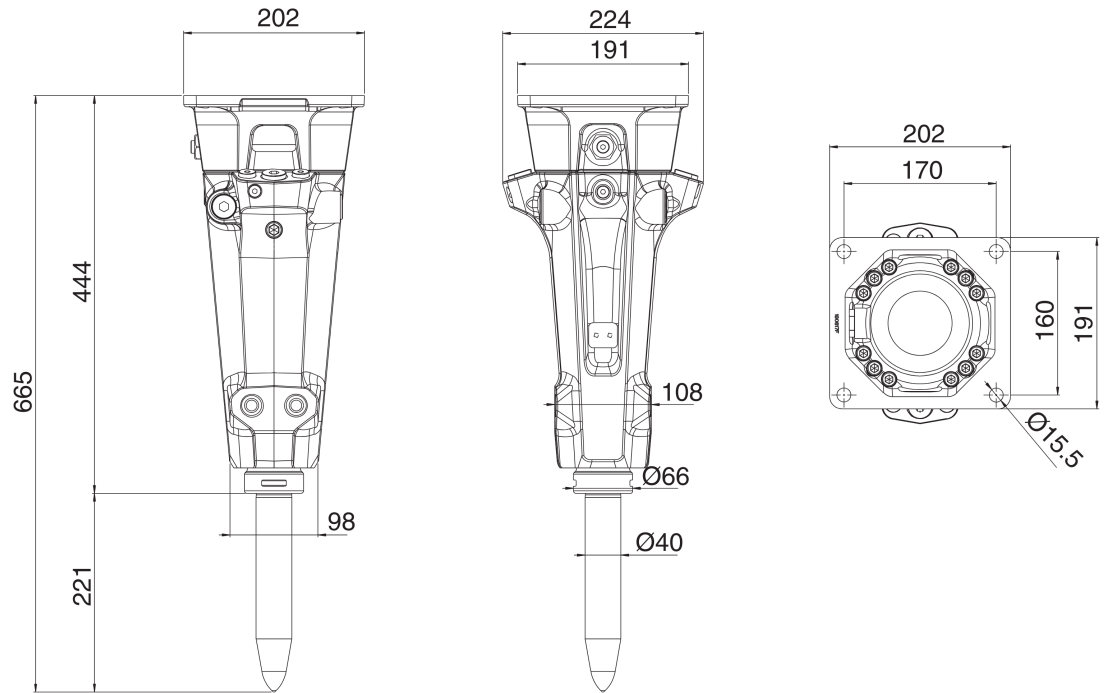

Specifications

Minimum working weight	50 kg (110 lb)
Minimum working weight with greasing device	64 kg (141 lb)
Impact rate	880...2650 bpm
Operating pressure	110...150 bar (1595...2175 psi)
Pressure relief, max	220 bar (3190 psi)
Oil flow range	10...31 l/min (2.6...8.2 gal/min)
Back pressure, max	30 bar (435 psi)
Input power	7.7 kW (10 hp)
Tool diameter	40 mm (1.57 in)
Mini Excavator weight, allowed range	0.6...2.8 t (1300...6200 lb)
Skid steer, robot weight, allowed range	0.4...1.9 t (900...4200 lb)
Noise level, measured sound power level, LWA	117 dB (117 dB)
Noise level, guaranteed sound power level, LWA	119 dB (119 dB)

Specifications are subject to change without notice



Developed and tested in the harshest of conditions, the foundations of Rammer products are quality, operational reliability and maximized productivity. Long working life and durability ensure our attachments can be used efficiently and economically no matter the challenge at hand, making Rammer a sustainable choice.

**GROUND
TEC
EQUIPMENT**

Sydney
Ground Tec Equipment
16 Garema Cct, Kingsgrove NSW 2208

Newcastle
Ground Tec Equipment
27 Jura St, Heatherbrae NSW 2324

**Ram
mer®**

Contact : 02 9642 2030 / breakers@groundtec.com.au