

RAMMER 777E



EXCELLENCE LINE

FACTORY
INSTALLED
RD3 FOR
MYFLEET

CBE (CONSTANT
BLOW ENERGY)

MEMBRANE TYPE
ACCUMULATORS

SINGLE BODY DESIGN
WITHOUT TIE RODS

INTEGRATED TOOL BUSHINGS
AND THRUST RING (3 IN 1)

EXCELLENCE LINE HITS SMARTER

The Rammer Excellence Line is a set of state-of-the-art hydraulic hammers for all your rock breaking needs. All Excellence Line hammers now have integrated smart technology for easier fleet management and more efficient processes.

Read more about the product from
www.rammer.com/excellence

**Ram
mer**[®]

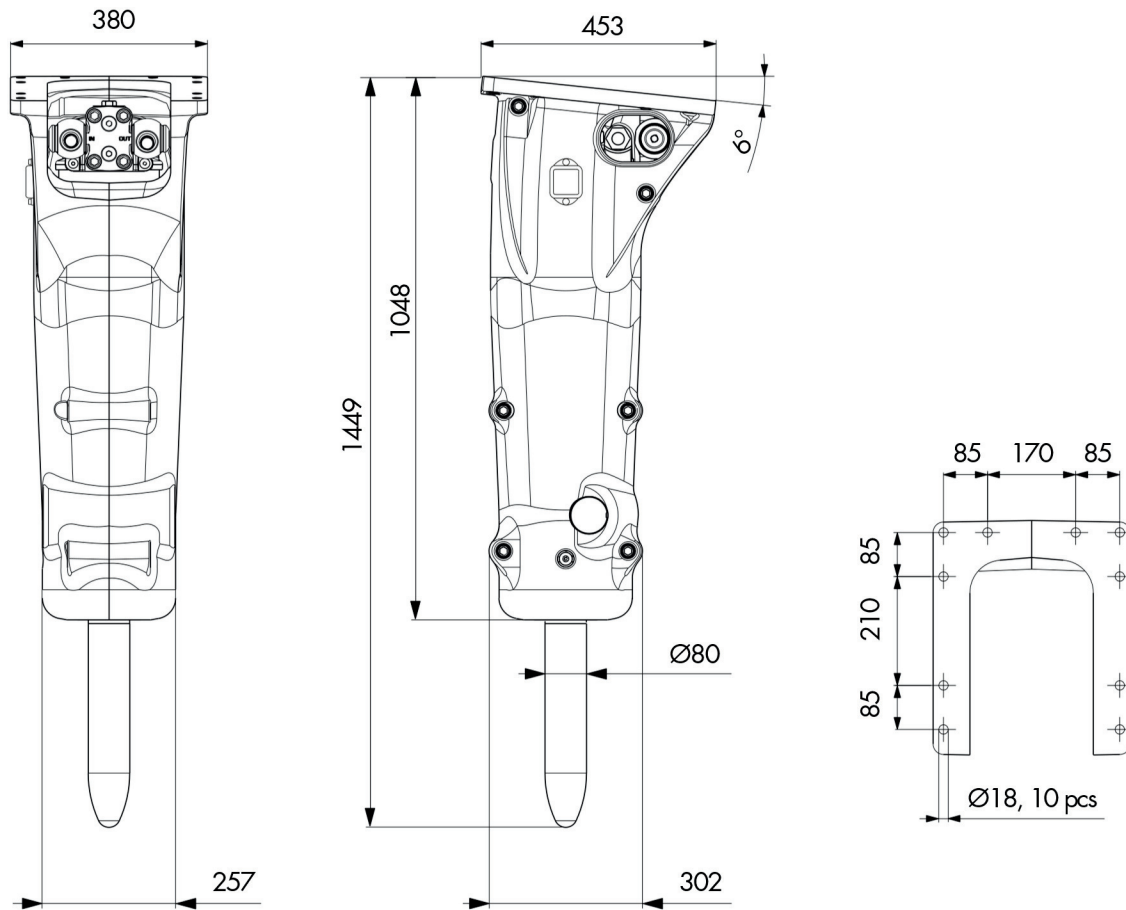

SPECIFICATIONS

Minimum working weight, flange mounted, kg (lb)	390 (860)
Impact rate, bpm	500-1700
Operating pressure, bar (psi)	90-140 (1305-2030)
Pressure relief, max bar (psi)	220 (3190)
Oil flow range, l/min (gal/min)	40-120 (10.6-31.7)
Back pressure, max bar (psi)	20 (290)
Input power, kW (hp)	28 (38)
Tool diameter, mm (in)	80 (3.15)
Minicavator weight, allowed range t (lb)	4.3-9.5 (9500-20900)
Skid steer, robot weight, allowed range t (lb)	2.6-6.3 (5700-13900)
Noise level, measured sound power level, LWA dB	120
Noise level, guaranteed sound power level, LWA dB	124

TOOLS

Chisel	Spade
Moil point	Compacting plate
Pyramid	

PARTS

Service kit 1
Special tool grease

Specifications are subject to change without notice

GROUND TEC
EQUIPMENT

Sydney

Ground Tec Equipment
16 Garena Cct, Kingsgrove NSW 2208

Newcastle

Ground Tec Equipment
27 Jura St, Heatherbrae NSW 2324

Rammer[®]

Contact : 02 9642 2030 / breakers@groundtec.com.au