

RAMMER 5017E



EXCELLENCE LINE

FACTORY
INSTALLED
RD3 FOR
MYFLEET

RAMVALVE

RAMLUBE II (OPT.)

MEMBRANE TYPE
ACCUMULATOR

DOUBLE TOOL RETAINING
PIN STRUCTURE

FBE (FIXED BLOW ENERGY)

UPGRADED GREASING
FOR TOOL BUSHINGS

VIDAT TIE RODS

EASY IBP ADJUSTMENT

HARD WEAR PLATES

SIMPLE LOWER TOOL
BUSHING ROTATING OR
REPLACEMENT

ACCUMULATOR FILLING
POINT ON SIDE

STROKE SELECTOR

EXCELLENCE LINE HITS SMARTER

The Rammer Excellence Line is a set of state-of-the-art hydraulic hammers for all your rock breaking needs. All Excellence Line hammers now have integrated smart technology for easier fleet management and more efficient processes.

Read more about the product from
www.rammer.com/excellence

**Ram
mer**[®]

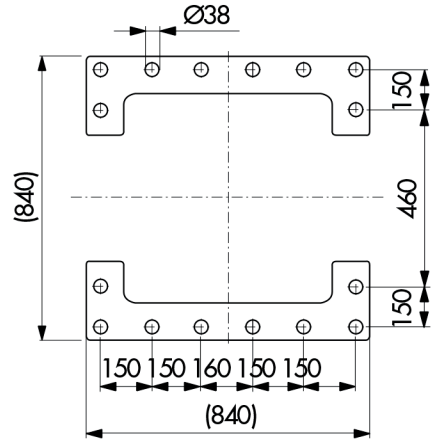
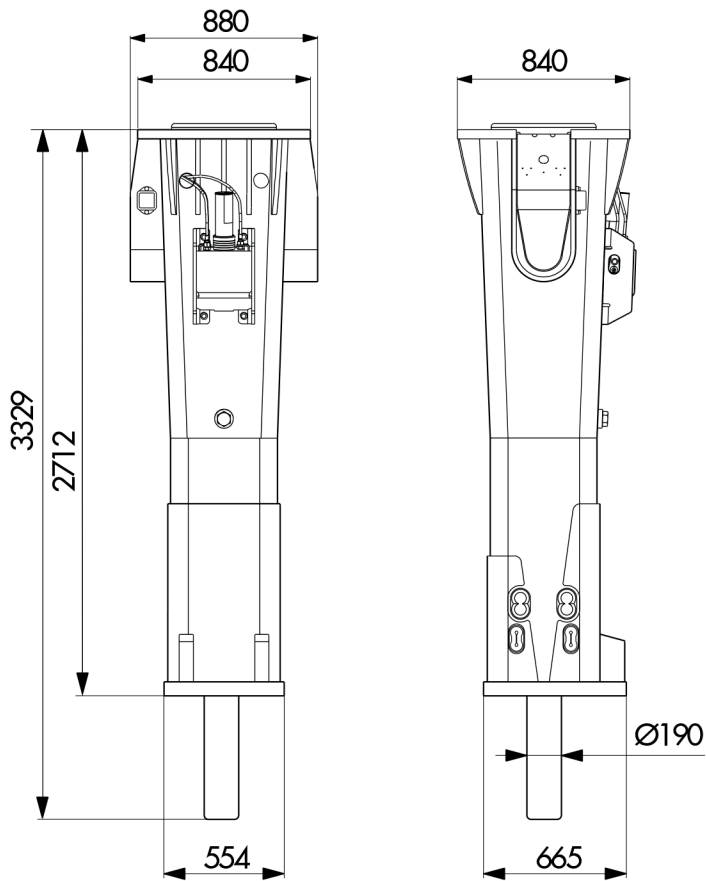

SPECIFICATIONS

Minimum working weight, kg (lb)	4750 (10470)
Impact rate, Long Stroke, bpm	370-530
Impact rate, Short Stroke, bpm	450-620
Operating pressure	160-170 (2320-2465)
Pressure relief, min bar (psi)	220 (3190)
Pressure relief, max bar (psi)	230 (3335)
Oil flow range, l/min (gal/min)	280-380 (74.0-100.4)
Back pressure, max bar (psi)	10 (145)
Input power, kW (hp)	108 (145)
Tool diameter, mm (in)	190 (7.48)
Carrier weight, allowed range, t (lb)	43-80 (94800-176400)
Noise level, measured sound power level, LWA, dB	122
Noise level, guaranteed sound power level, LWA, dB	126

TOOLS

Chisel	Pyramid
Hard rock chisel	Blunt
Limestone chisel	Super blunt
Moil point	

PARTS

Service kit 1	Special tool grease
Service kit 2	Meissel paste

Specifications are subject to change without notice

GROUND TEC
EQUIPMENT

Sydney
Ground Tec Equipment
16 Garema Cct, Kingsgrove NSW 2208

Newcastle
Ground Tec Equipment
27 Jura St, Heatherbrae NSW 2324

Rammer

Contact : 02 9642 2030 / breakers@groundtec.com.au